

**NAD**

**SERVICE  
MANUAL**

**MODEL**

**5120**

**BELT-DRIVE TURNTABLE**

<b>CONTENTS</b>	<b>PAGE</b>
<b>OPERATING CONTROLS AND FEATURES:</b>	
Figure 1: Front view	3
Figure 2: Back view	14
Figure 3: Tonearm	4
Figure 4: Tonearm features	4
<b>SPECIFICATIONS</b>	5
<b>DISASSEMBLY</b>	5-6
<b>ALIGNMENT</b>	8-9
Figure 5: Disassembly of case top (plinth)	5
Figure 6: Internal parts and features	7
Figure 7: Electrical diagram	10
Figure 8: Pickup cartridge wiring diagram	10
Figure 9: Exploded view; parts identification	11-12
<b>MECHANICAL AND ELECTRICAL PARTS LIST</b>	13 & 15

FIGURE 1 FRONT VIEW

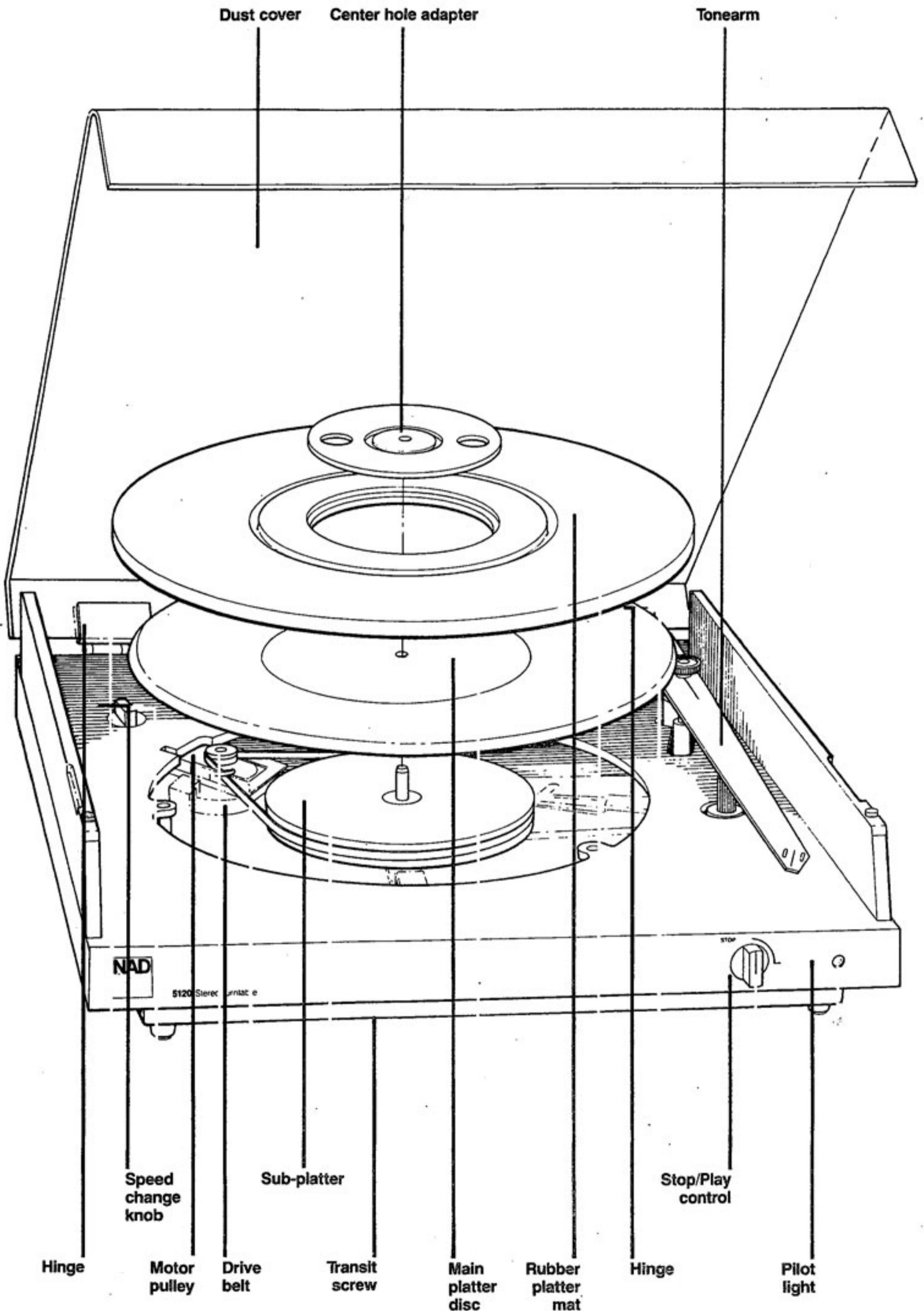

**FIGURE 3 TONEARM**

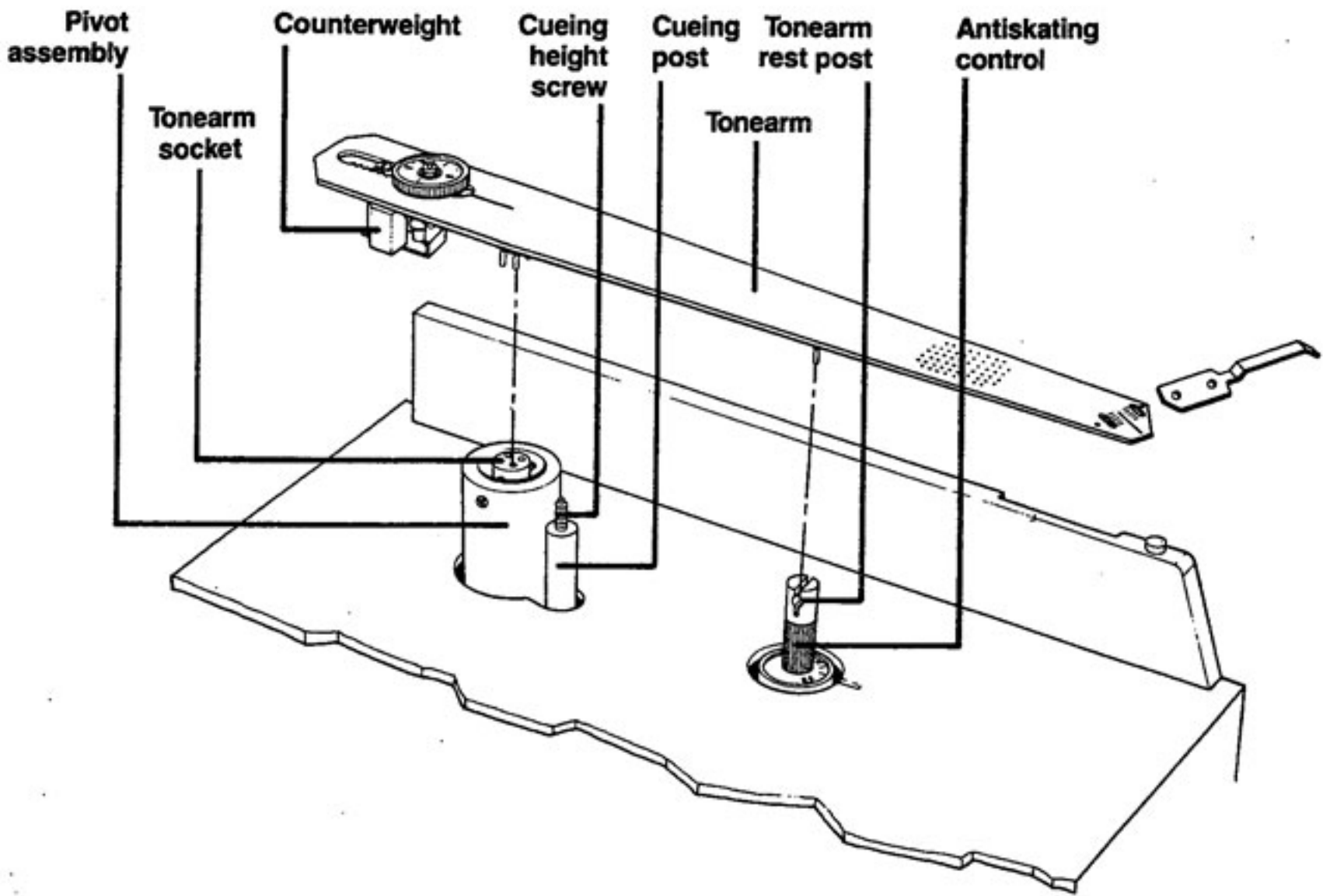

**FIGURE 4 TONEARM FEATURES**

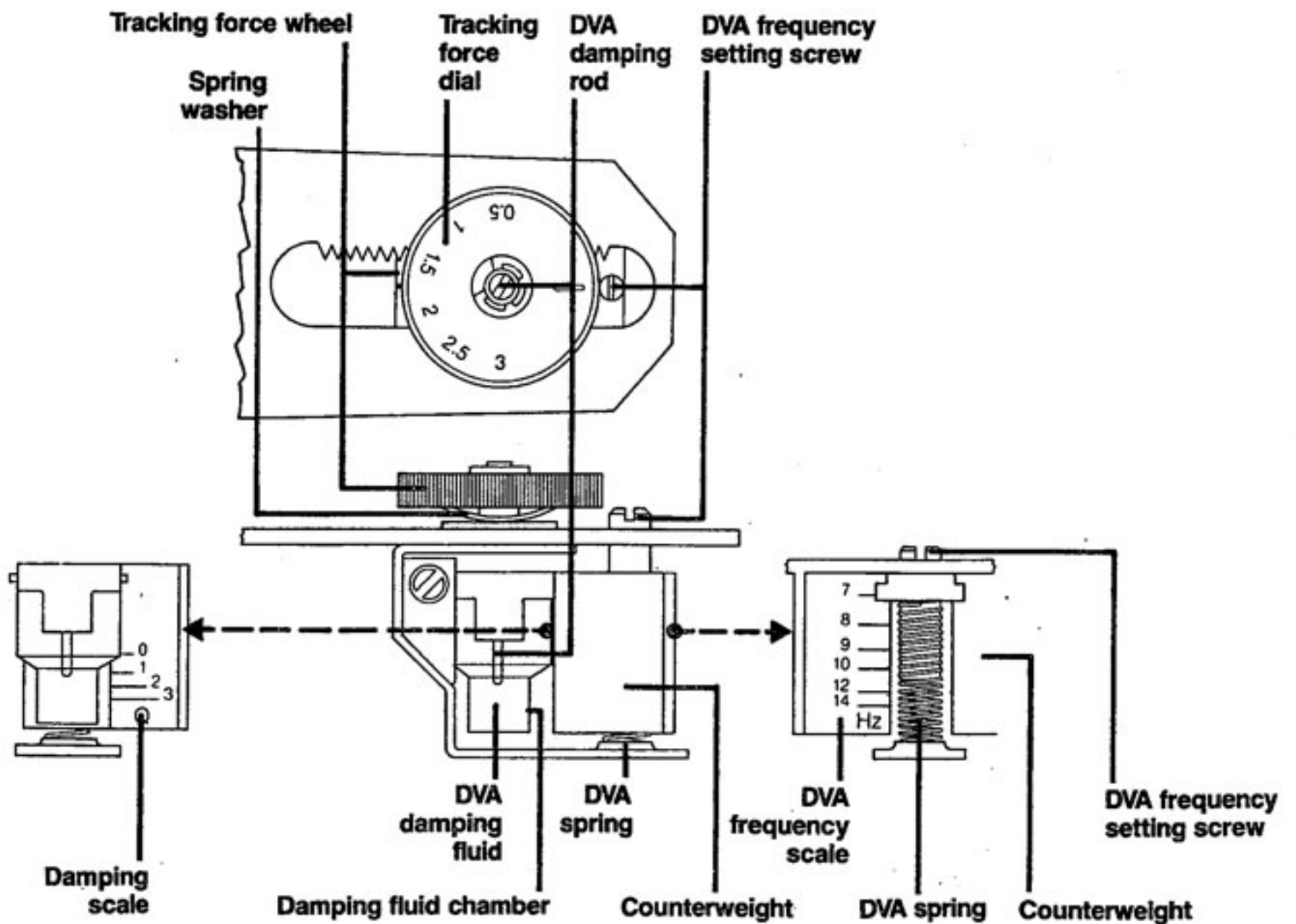

**SPECIFICATIONS**  
**NAD 5120 SEMI-AUTOMATIC**  
**BELT DRIVE TURNTABLE**

**TURNTABLE**

<b>Drive system</b>	Precision neoprene belt drive
<b>Motor</b>	Synchronous motor (360 rpm with 60 Hz power, 300 rpm at 50 Hz)
<b>Speeds</b>	33.3 and 45.1 rpm
<b>Speed accuracy</b>	±0.5%
<b>Wow and flutter</b>	0.07% DIN peak 0.04% WRMS
<b>Signal-to-noise ratio (rumble)</b>	-70 dB (DIN B weighted), -43 dB (DIN A unweighted)
<b>Suspension system</b>	Platter and tonearm rigidly mounted on subchassis floating on high-compliance springs.
<b>Suspension resonance</b>	Below 4 Hz

**TONEARM**

<b>Features</b>	Flat, flexible, interchangeable, statically balanced tonearm with Dynamic Vibration Absorber.
<b>Operation</b>	Semi-automatic (automatic lift and stop at end of record).
<b>Length</b>	27.8 cm (10 <sup>15</sup> / <sub>16</sub> in.) total length 20.8 cm (8 <sup>3</sup> / <sub>16</sub> in.), pivot to stylus
<b>Effective mass</b>	6 grams
<b>Overhang</b>	19.1 mm (¾ inch)
<b>Offset angle</b>	26°
<b>Lateral tracking error</b>	Zero at R=63.6 and 119.1 mm
<b>Maximum tracking error</b>	0.16°/cm. (0.4°/inch)
<b>Dynamic Vibration Absorber</b>	Spring-suspended counterweight with viscous damping
<b>Cartridge weight</b>	4 to 8 grams with counterweight in normal position; 2 to 4 grams with counterweight assembly reversed
<b>Vertical tracking force</b>	0 to 3 grams (0 to 30 milliNewtons)
<b>Antiskating range</b>	0.75 to 3 grams (7.5 to 30 mN)
<b>Cable capacitance</b>	150 pF

**DIMENSIONS**

<b>Width</b>	42 cm. (16½ in.)
<b>Height</b>	10.5 cm. (4⅛ in.)
<b>Depth (including knob and cover hinges)</b>	35.4 cm. (14 in.)
<b>Net weight</b>	5 kg. (11 lb.)
<b>Shipping weight</b>	6.5 kg. (14 lb. 5 oz.)

**NOTE:** All numbers in brackets refer to parts' positions called-out on diagrams, and to the complete Parts List included in this manual.

**1.00 EQUIPMENT DISASSEMBLY**

1. Disconnect power cord.
2. Pull the dust cover [64] upwards out of the hinges.
3. Pull the tonearm out of the connector.
4. Remove the 3 screws [105] fastening the case top [65] that are accessible after lifting off the adapter [61], the rubber mat [60] and the top platter [59].
5. Lean both thumbs on the bottom case [1], and by pulling the case top with the other fingers, release it gradually.
6. Remove retaining ring [109] from the transport screw. Unscrew the transport nut [37].
7. Using tweezers, release the spring [54] out of the suspension on the chassis [2].
8. Take off the belt [57] from the bottom platter.

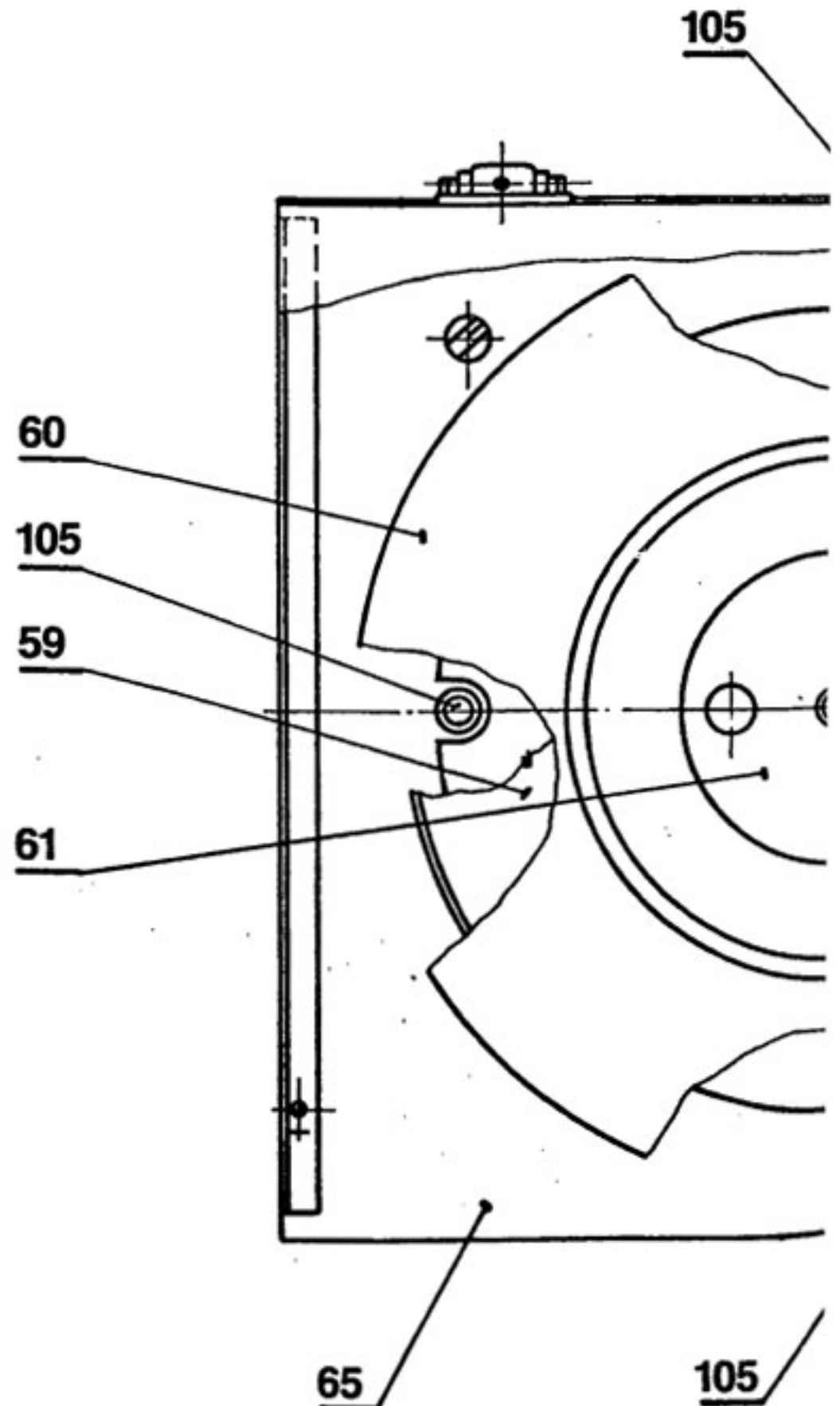

9. Pull out the bottom platter [58] from the bearing [14].
10. Unsolder five fine flexible wires from the bearing assembly [33] from lugs [51] placed on the right side of the bottom case. In some versions the wires are connected to a 5-pin DIN socket [51A], instead of to terminals.
11. Take off the connecting shaft [38] after pushing the chassis slightly backwards.
12. Pull the chassis assembly [1] out of the rubber cushions [36] on three springs [34] which are fastened on the bottom case [1].

When *assembling* the equipment reverse the above procedure.

**FIGURE 5 DISASSEMBLY OF CASE TOP (PLINTH)**

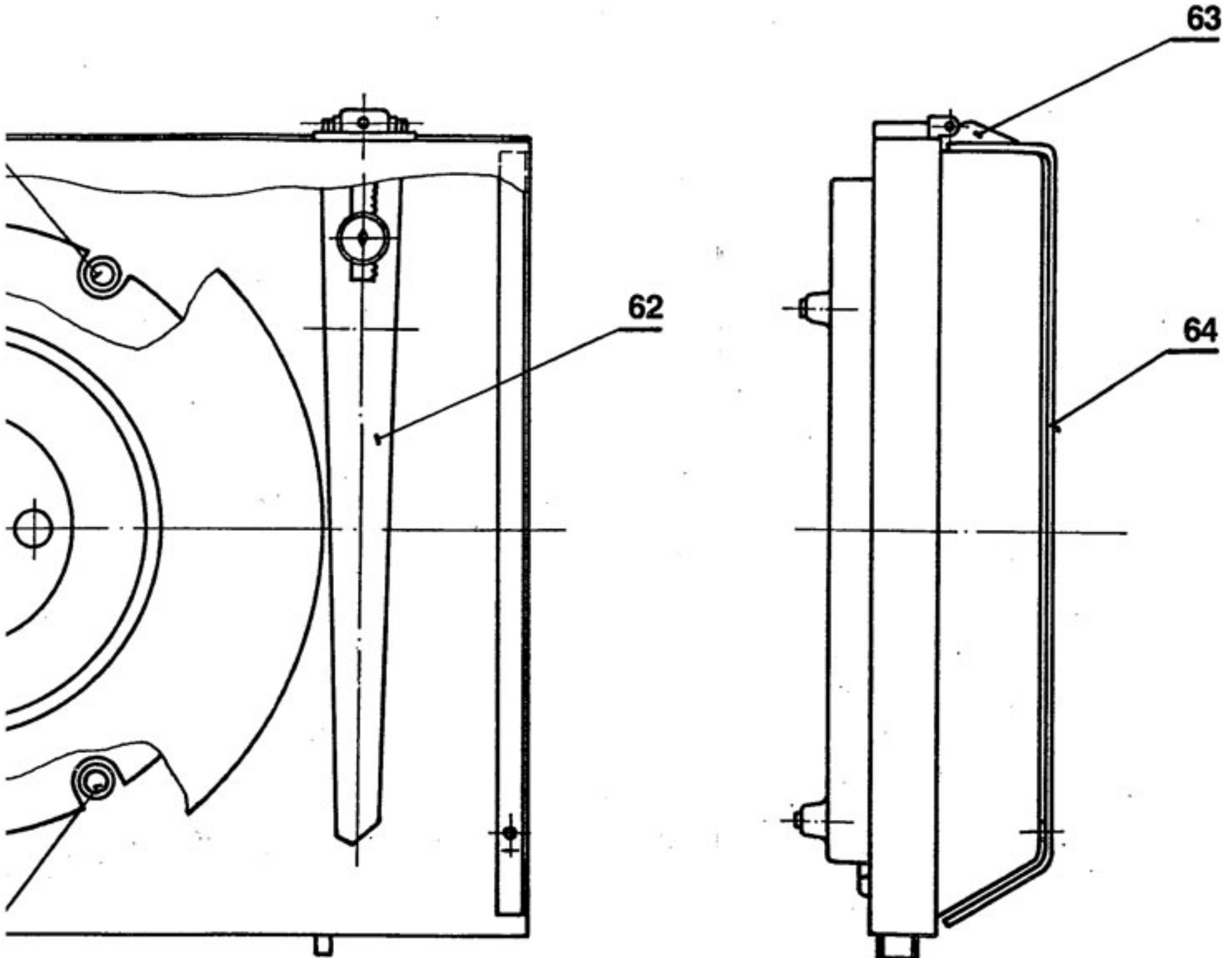
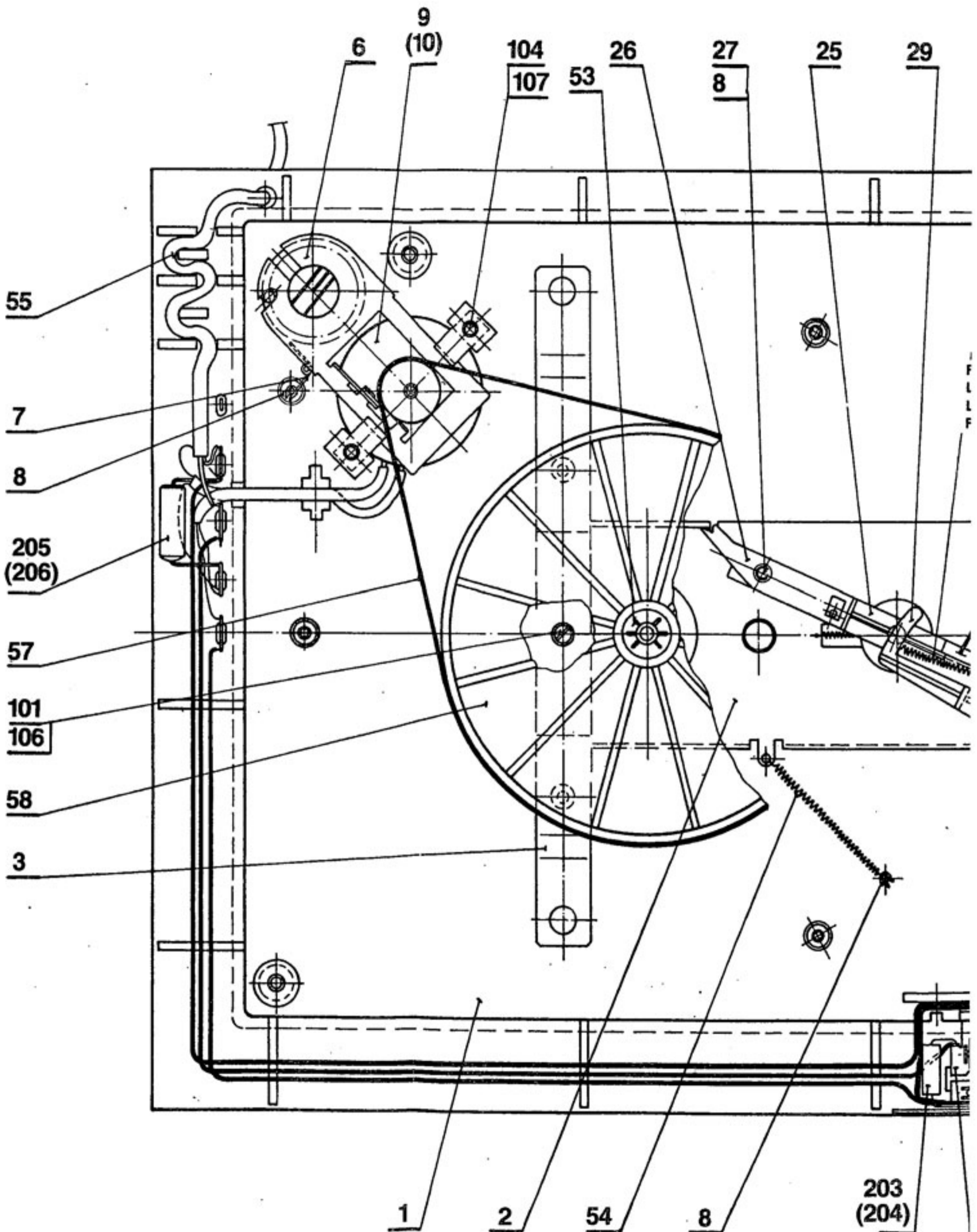

FIGURE 6 INTERNAL PARTS AND FEATURES



## 2.00 OPERATIONS ON THE CHASSIS

1. **Removing the tonearm bearing assembly:** Release the screw [103] in the cutout of the bottom part and pull the bearing assembly out of the bearing. Slide the rod [32] out of the suspension.
2. **Removing the connector:** Loosen one of the pivot screws [68] to set the connector [67] free. Check if the flexible wires soldered to the pins are not broken or disconnected. The wires are fixed between terminals by a rubber insert.

### 3. How to re-install connector:

- a. to assist in holding the socket [67], insert a spare 4-pin male DIN plug.
  - b. put the connector [67] into the bearing assembly [33] so that the triangle mark faces the tonearm rest [23].
  - c. hold the connector centered and lean it by one tip to the pit of the pivot screw [68].
  - d. tighten the second screw [68] until just snug.
  - e. loosen either screw [68] approximately 90°.
  - f. secure both screws [68] with nail polish (lacquer).
  - g. if the connector [67] is not centered, adjust its position by both pivot screws [68]. When properly adjusted, the connector should move freely back and forth in the bearing, but with as little lateral motion as possible. The flexible connector wires must be secured between the terminals by a rubber insert and faced towards the bottom opening where they should pass through freely. The wires must not interfere with arm holder rotation or movement of the connector.
4. **Lubrication of the bearings:** The platter and tonearm bearings are self-lubricated, so they should not require any regular maintenance. If necessary both platter and tonearm bearings can be lubricated with a small amount of fine machine oil.

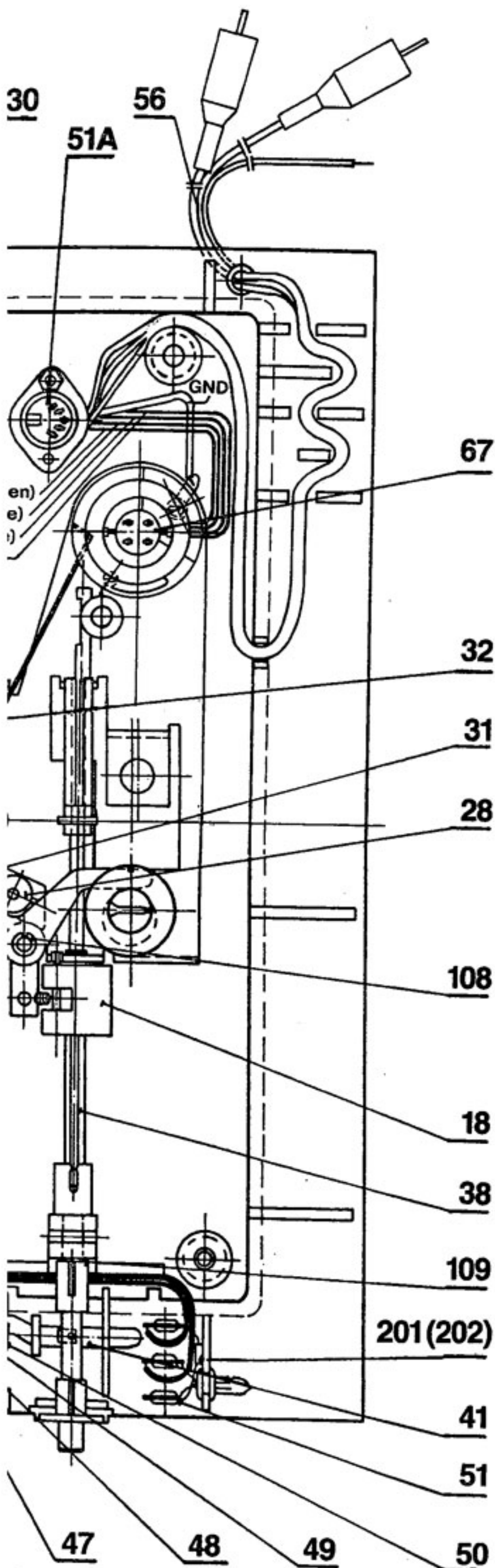



### 3.00 FUNCTION CHECKING

1. **Tonearm lifter [43] and [44]:** The stylus should drop on the record grooves from the lifted position within  $1.5 \pm 0.7$  seconds. If it drops faster, add more silicon oil to the inside surface of the lifter. If it drops slower, remove some of the oil. After any operation on lifter move it slightly up and down and turn it several times in order to distribute silicon oil uniformly and to ensure perfect lifter operation.

The height of the tonearm lifter is adjustable to compensate for different cartridge body heights. If a cartridge has been installed in the arm, turn the threaded shaft in the top of the lifter so that the stylus tip is 5 to 7 mm above the record surface when the arm is in the raised position.

2. **Switching-off:** Switching-off mechanism should not require any adjustment. Only the starting position of rotating switching-off lever [25] should be checked as follows:

Move the tonearm [62] towards the record center. When the distance between the stylus and the spindle is approximately 152 mm (6") (just before rim of LP record), visible rotation of switching-off lever [25] pulled by rod [32] must be observed.

When the stylus is 63 mm (2½") away from the record center, the distance between the stopper tip [26] on switching-off lever and the platter axis should be exactly 19 mm (¾"). To ensure proper function of the switching-off lever the stopper [26] movement must be absolutely free.

3. **Antiskating (side force compensation):** The antiskating is set during production so that its side force is approximately 10% of vertical tracking force (VTF), if the same data are set on the antiskating [22] and VTF [72] dials. The antiskating force should be almost constant when moving the tonearm across the record grooves' field. The antiskating starts to operate at the rim of 30 cm (12") diameter record only. When the arm is positioned between record and arm rest, the antiskating is out of function and the VTF can be set in this place easily, without any side component.
4. **Speed change:** Chassis [1] is to be fixed by transport nut [37], top platter is removed. Check whether the belt slips easily from one pulley stage to the other without twisting or permanently touching the slider.
5. **Pulley position:** The distance between the lower surface of the top pulley stage [11] or [12] and lower vertical part of the slider [6] should be 0.2–0.3 mm; set it with steel plate 0.25 mm thick inserted between those parts. If the belt rubs speed change slider, adjust height of pulley [12] on motor shaft.
6. **Control start-stop knob [42]:** When the turntable is off, the knob must be vertical. When playing, the mark line faces to the right horizontally. After turning it back about 15° the knob returns slowly to off-position, being pulled by spring [21]. The turntable is then switched off and the tonearm lifted. The knob return time to the off-position should take approximately 1 second. If less, some silicon oil should be added. If the tonearm lifts too slowly, remove some silicon oil from the inner friction surface of the brake [20].

7. **Tonearm check:** if the tonearm will be turned upside-down for more than a few minutes, unscrew the DVA damping rod [18] (the small threaded rod located in the center of the tracking force wheel) until it protrudes at least 2 mm (⅛") above the wheel, in order to seal the oil chamber and prevent leakage.

Check the viscous oil amount in the damping chamber [20]. The level should be between the marks 0 and 1 on the damping scale (Q) which corresponds to 6mm height of the damping oil. In case the oil has leaked out it should be refilled with NAD oil, Part No. 8AV88600, or with a universal one having viscosity 180,000 CP (e.g., Wacker AK 18000). The oil should be refilled through the damping chamber aperture after unscrewing the damping rod by using a common syringe.

If a cartridge has been installed, turn the tracking force wheel to balance the arm, and then set the vertical tracking force. (If the white DVA tuning screw obstructs the motion of the counterweight, substitute a shorter screw.) If the cartridge weighs less than 4 grams and cannot be balanced, rotate the counterweight assembly 180 degrees. (Turn in the DVA tuning screw, press down hard on the tracking force wheel in order to flatten the spring washer beneath it, and rotate the assembly.)

Adjust the Dynamic Vibration Absorber (DVA) as described in the DVA Tuning leaflet, or use nominal settings of 10 Hz for the tuning frequency and 2 for the damping ratio. (In each case, align the top of the adjusting screw with the desired scale setting.)

Check the geometric alignment of the cartridge with respect to rotation and overhang (see customer instruction manual). Use an alignment protractor to check the offset angle of the cartridge.

Check the connection of the wires at the back of the cartridge for a snug friction fit (crimp to tighten if necessary) and correct connection according to the standard colour code.

8. **Checking the position of the floating chassis suspension:** In operating position, when transport nut and platter are released, and the record and tonearm are put on, the vertical clearance between the lower surface of the rubber mat [60] and the case top [65] around the whole rim must be 3 mm (⅛") minimum. The horizontal clearance between chassis-parts and the case top [65] should be also 3 mm. Vertical clearance can be increased or reduced by inserting or removing washers [35] between rubber cushions [36] and chassis holder, or by bending the holder ends slightly.
9. **Signal-to-noise ratio:** Measure with the test record (Dennon XG 7004) according to DIN 45/544 Standard. When using DIN A filter, signal-to-noise ratio should be better than -40 dB. Average value is measured, and random deviations must not exceed +5 dB.
10. **Wow and flutter, speed:** Measure with wow and flutter meter and test record (Dennon XG 7004). Maximum acceptable drift (speed deviation) is 0.5%, and wow and flutter maximum  $\pm 0.15\%$  (DIN). If more, check the platter bearing, belt and motor.

Further instructions for settings and maintenance are provided in the customer's manual (INSTRUCTIONS FOR INSTALLATION AND OPERATION).

FIGURE 7 ELECTRICAL DIAGRAM

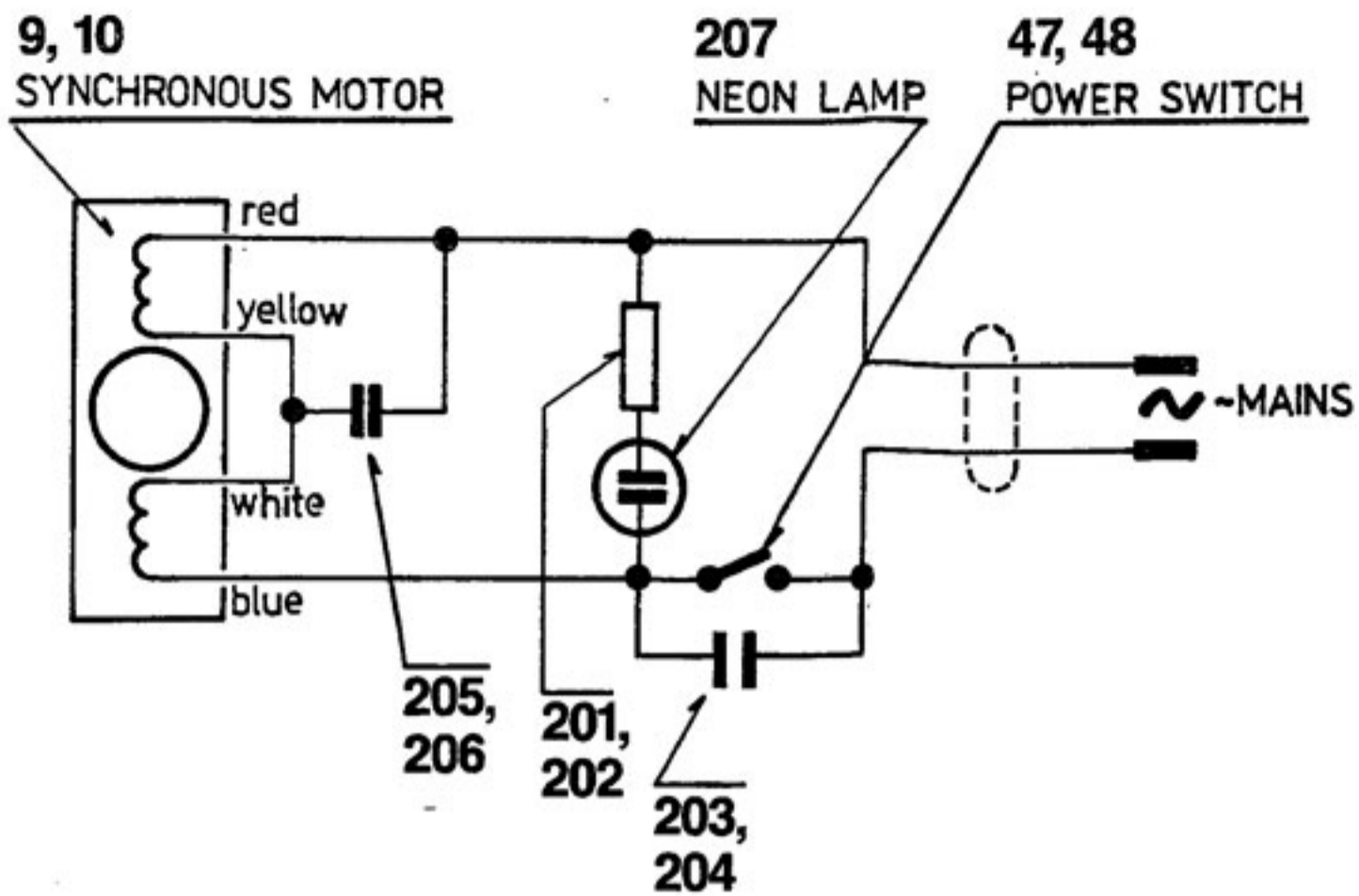
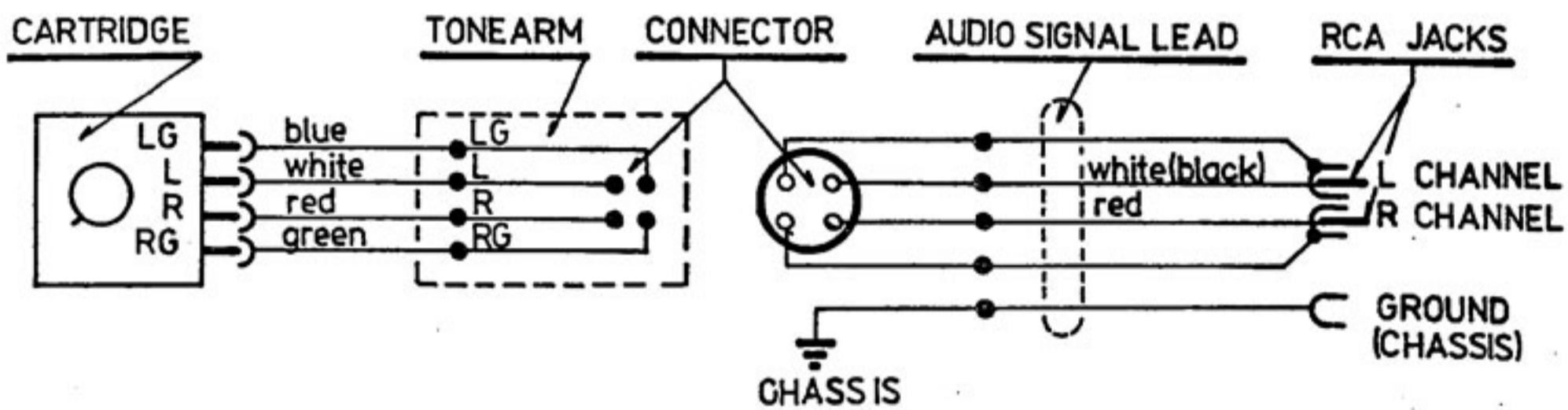
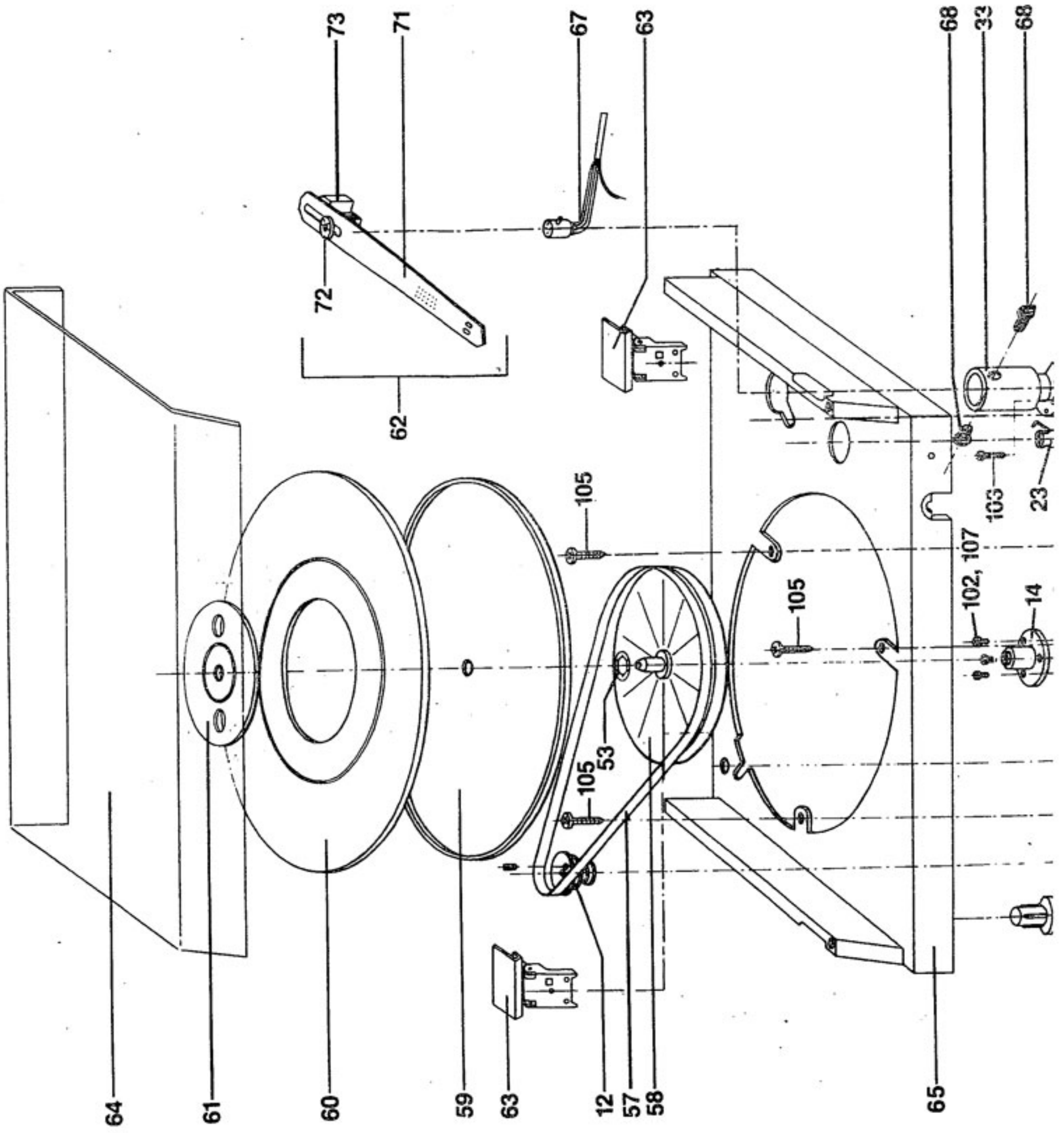
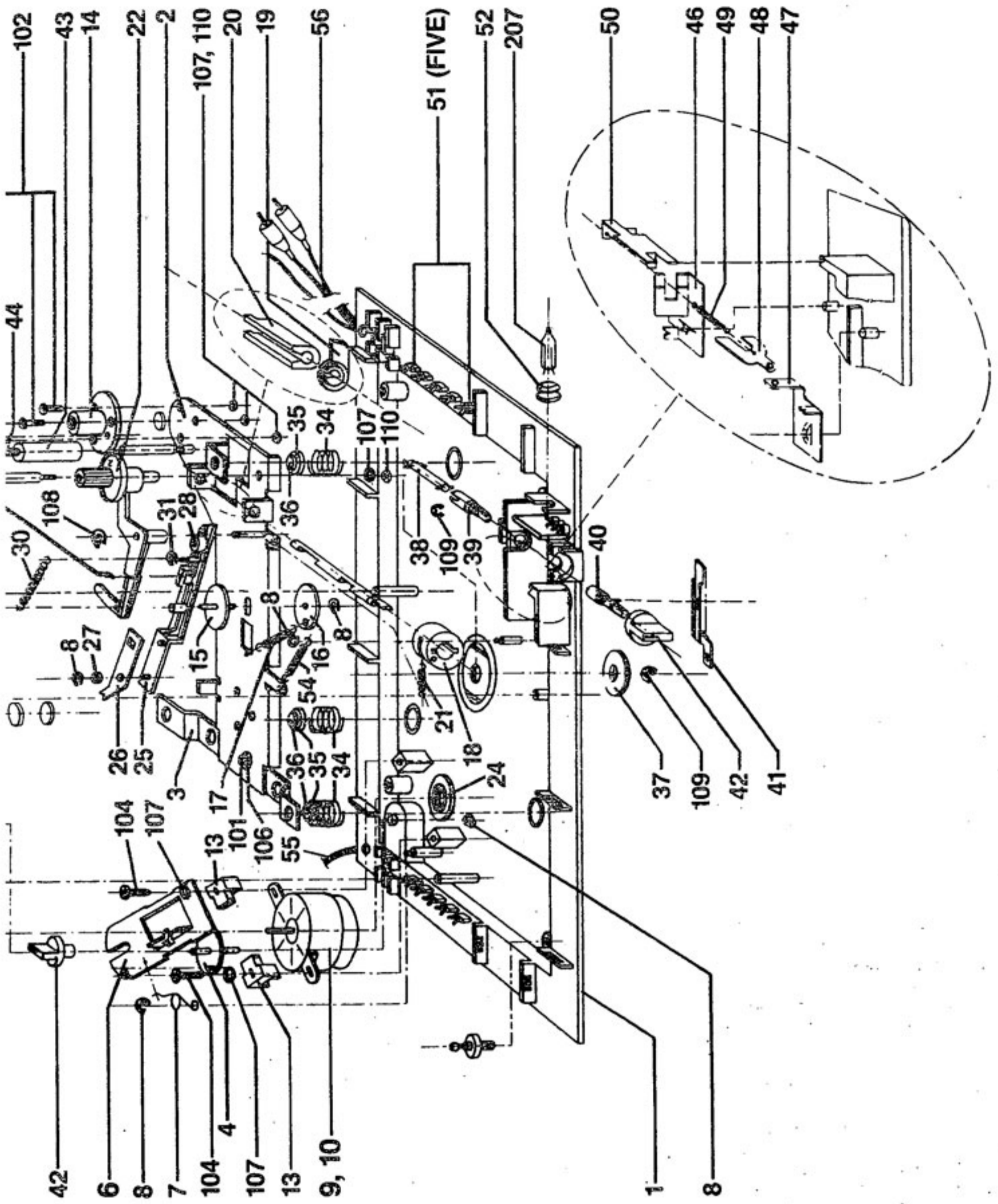

FIGURE 8 PICKUP CARTRIDGE WIRING DIAGRAM







## PARTS LIST

### A. BASIC/PRIMARY/SET

	CALLOUT NO.	DESCRIPTION	PART NO.
	7.	SPRING (Speed Change)	7AA 791 38
	8.	E-RING (3 mm dia)	8AA 024 000
(EUROPE)	9.	SYNCHRONOUS MOTOR (Drive)	SPJ NAD 5120 220 V/50 Hz
(USA)	10.	SYNCHRONOUS MOTOR (Drive)	SPJ NAD 5120 120 V/60 Hz
(EUROPE)	11.	PULLEY 50 Hz (Motor)	8AA 886 006.01
	17.	SPRING (Aut. Stop Lever)	7AA 786 31
	21.	SPRING (Control Shaft)	8AA 786 008
	23.	TONEARM REST ASSY (Chassis)	8AF 140 006
	30.	SPRING (Antiskating)	89A 786 25
	31.	RETAINING RING (2 mm dia)	7AA 024 00
	33.	TONEARM BEARING ASSY (Chassis)	8AF 826 001
	34.	SPRING (Chassis Support)	89A 791 11
	40.	EXTENSION SHAFT B (Control)	8AF 242 000
	41.	SLIDER (Power Switch)	8AA 185 042
	42.	KNOB ASSY (Control + Speed Change)	8AF 243 017
	49.	SPRING (Power Switch)	89A 786 16
	57.	BELT (Drive)	4 × 0,8 × 160, 42 Sh
	60.	RUBBER MAT (Turntable)	89A 221 05
	62.	TONEARM ASSY, COMPLETE (With Slots for Cartridge)	8AN 625 010.01
	64.	DUST COVER	89A 698 05
	67.	TONEARM CONNECTOR ASSY	2WK 180 10
	73.	COUNTERWEIGHT ASSY (Dynamic Vibration Absorber)	8AF 942 006
	207.	NEON LAMP POWER (100 V)	PG 100-19 LD

### B. FULL SET

	CALLOUT NO.	DESCRIPTION	PART NO.
	1.	CASE BOTTOM PART	8AF 693 019
	2.	CHASSIS ASSY (Case, Bottom Part)	8AF 115 027
	3.	HOLDER (Chassis)	8AA 664 001
	4.	CAM (Speed Change)	8AA 260 036
	5.	WASHER (Speed Change)	7AA 064 38
	6.	SLIDER (Speed Change)	8AA 189 006
(USA)	12.	PULLEY 60 Hz (Motor)	8AA 886 006.02
	13.	SLIDER GUIDE (Speed Change)	8AA 261 034
	14.	BEARING HOLDER (Platter, Tonearm)	8AF 261 017
	15.	SLIDER (Aut. Stop Lever)	8AF 248 010
	16.	WASHER (Aut. Stop Lever)	8AA 064 012
	18.	CONTROL SHAFT ASSY (Chassis)	8AF 725 002
	19.	BUMPER (Aut. Stop)	8AA 683 026
	20.	BRAKE (Control Shaft)	8AA 259 006
	22.	CAM ASSY (Antiskating)	8AA 797 000
	24.	FELT WASHER (Motor-Case)	89A 303 02
	25.	LEVER (Aut. Stop)	8AA 185 041
	26.	STOPPER (Aut. Stop Lever)	8AA 182 007
	27.	PLASTIC WASHER (Aut. Stop Lever)	7AA 064 58
	28.	RING (Aut. Stop Lever)	8AA 017 021
	29.	LEVER (Antiskating)	8AA 185 040
	32.	ROD (Antiskating)	8AA 188 009
	35.	WASHER (Chassis Height Adj.)	8AA 064 011
	36.	CUSHION (Chassis Spring)	89A 424 01
	37.	TRANSPORT NUT (Chassis/Case Bottom)	8AA 035 010
	38.	CONNECTING SHAFT (Control)	8AA 252 009
	39.	EXTENSION SHAFT A (Control)	8AA 260 035
	43.	LIFTER TUBE (Control)	8AA 906 045
	44.	THREAD ROD (Arm Lifter)	8AA 010 008
	45.	CUSHION (RUBBER) (Arm Lifter)	8AA 015 002
	46.	SWITCH HOLDER (Power Switch)	8AA 668 018
	47.	SWITCH CONTACT (Power)	8AF 468 005
	48.	SWITCH CONTACT (Power)	8AF 468 004

FIGURE 2 BACK VIEW

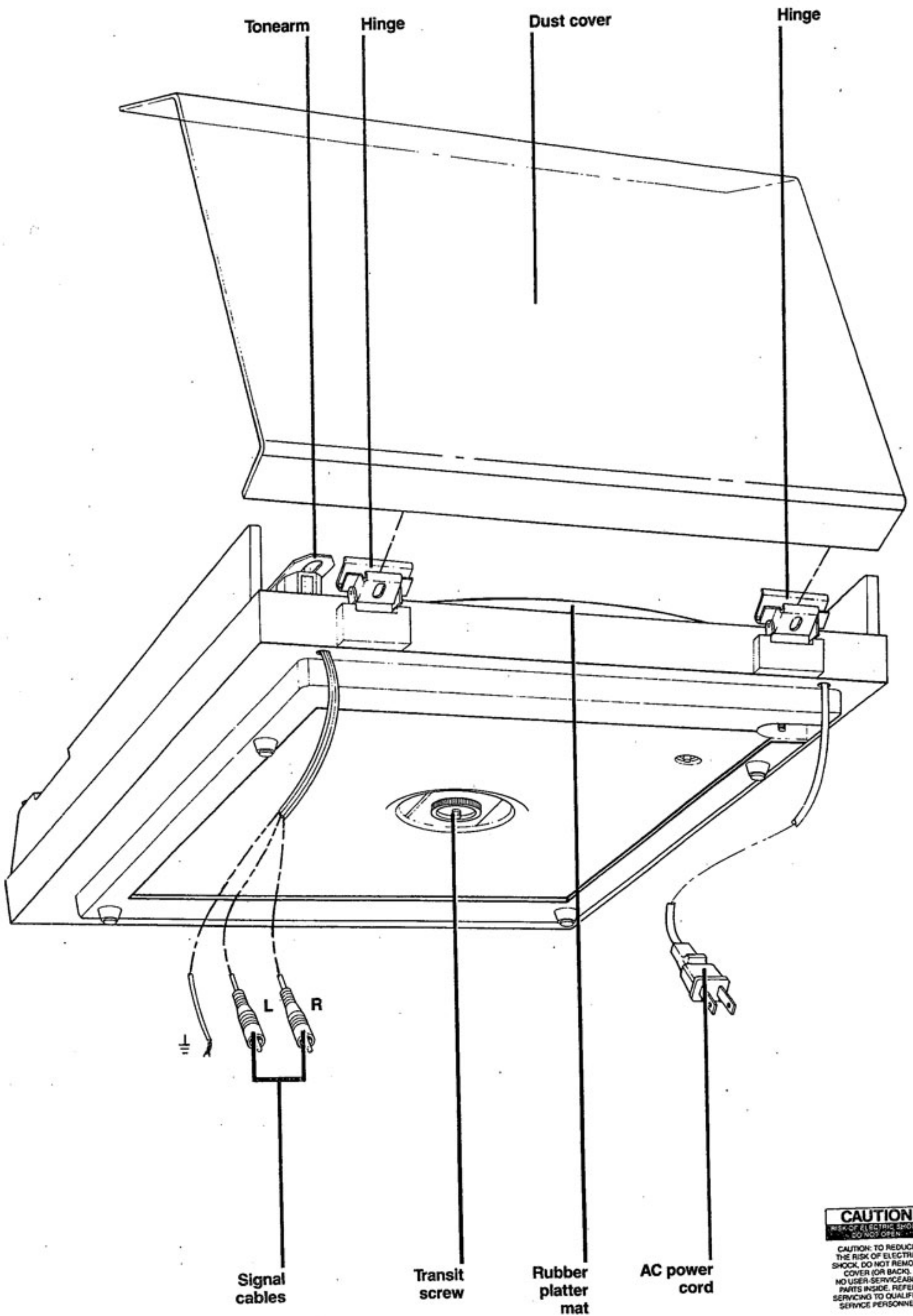

**CAUTION**  
RISK OF ELECTRIC SHOCK  
DO NOT OPEN

CAUTION: TO REDUCE THE RISK OF ELECTRIC SHOCK, DO NOT REMOVE COVER (OR BACK). NO USER-SERVICEABLE PARTS INSIDE. REFER SERVICING TO QUALIFIED SERVICE PERSONNEL.



© 1984 BY NAD 215 PRINTED IN CZE

**NAD ELECTRONICS**  
BOSTON/LONDON